

## Care & Finishing

Your GlassCraft® door has been handcrafted to last for years. And like any piece of fine furniture, it needs proper finishing and periodic maintenance to keep it in top condition. The most important single method to ensure the door's longevity is to apply a high quality stain and finish. Please note that failure to follow GlassCraft's care & finishing recommendations will void the door's warranty.

## Finishing Options for Wood Doors

Because GlassCraft doors are crafted from beautiful hardwoods, you can choose from a wide variety of stain or paint possibilities. Paint dealers have a broad selection of color chips on hand to demonstrate the look you can achieve when staining fine wood.

## Upon Receipt Of Door

Inspect your door thoroughly. Immediately check for squareness or warp. Do not cut, fit, or hang any door with any noticeable damage or defects. If any type of problem is found, notify the company from which you purchased the door for further instructions.

## Storage & Handling

1. Before installing, allow 24–48 hours for the door to adapt to the general humidity and temperature conditions of your area.
2. Doors should always be stored flat, in a clean, dry, well-ventilated room. Protect from dirt, water, and abuse. If stored for long periods, doors should be sealed with a high quality sealer or primer.
3. Doors should be stored in a dry area, and must not be exposed to abnormal heat, direct sunlight, direct moisture, or extreme dryness or humidity.
4. Deliver to your building site after the plaster and cement are completely dry. Avoid prolonged exposure to heated or air-conditioned environments prior to finishing.
5. If the doors are to be stored on the job site, all ends and edges must be sealed with a wood sealer in order to prevent moisture absorption.
6. Doors should always be handled with clean hands or while wearing clean gloves, to prevent dirt and oils from penetrating the wood grains.
7. Doors should be lifted and carried, not dragged in order to prevent damage to the wood surface.

## Preparation for Finishing

1. Prior to finishing, ensure that the building atmosphere is dried to a normal, interior relative humidity. Ensure that the doors have been allowed to equalize to a stable moisture content.
2. Doors must be completely finished on all 6 sides prior to final installation. **Installation of an unfinished door will void the warranty.**
3. To assure uniform moisture exposure and dimensional control, ALL surfaces must be treated equally. This includes front and back, top, bottom, and 2 sides.
4. Before finishing, cut, fit, and hang the door. Then remove the door and any hardware prior to finishing. When trimming the door, do not remove more than 1" from the bottom rail and/

or 1/2" from the top rail of the door. Do not reduce the width of the door by removing more than 1/2" from either side edge. **Removal of more than these amounts from the door will void the warranty.**

5. Before applying the first finishing coat, sand entire surface lightly to remove handling marks, raised grain, or other undesirable blemishes. Use 120 to 180 grit sandpaper, and always sand in the direction of the grain. Spot sanding can cause the finish to appear splotchy.
6. After sanding, clean the entire door with a clean cloth to remove all dust or foreign debris. (Avoid caustic or abrasive cleaners).
7. Certain species of wood contain chemicals which react unfavorably with certain finishes, causing dark stain spots. Where possible, the finish selection should be tested prior to complete application.
8. Avoid very dark stains or dark colored paints on door surfaces exposed directly to sunlight. Dark colors induce warpage.
9. Properly finish the entire door. Coat all 6 edges (including top, bottom, sides, and face surfaces) with each application. Adequate drying time between coats must be allowed, as the door must be dry before the next finishing step.

## Exterior Finishing

**CAUTION:** GlassCraft Door Company does not evaluate all of the available paints, stains or application requirements. Contact your paint dealer for systems best suited for your geographic region. Select only top quality finishes, and follow all of the finish manufacturer's instructions completely.

## Stain-and-Clear Finish

1. To color stain and seal, make first coat a stain or stain-and-sealer coat. All stain and clear finishes will perform better if protected from the direct effects of sunlight and moisture weathering, thereby requiring refinishing less frequently.
2. Make second coat a top quality sanding sealer or top coat material. A urethane-based finish system with UV inhibitors is an excellent choice for a door finish. Be sure the door surface to be finished is satisfactory in both smoothness and color after each coat before applying the next coat.
3. Lightly sand with 180 to 220 grit sandpaper or #0000 steel wool between each top coat. Remove dust before re-coating.
4. Minimum of 3 top coats (in addition to the base stain coat) on all 6 edges is required for proper protection.

Recommended staining and finishing steps:

- Remove handling marks and sand with the grain direction
- Treat raw wood with a penetrating stain
- Repeat penetrating stain as required for desired color
- First coat of sanding sealer or top coat
- Fine sand by hand
- Second coat of top coat
- Fine sand by hand
- Third coat of top coat

## Paint Finish

1. To paint finish your door, use a solvent based primer coat and a compatible solvent based finish coat.
2. Sand all surfaces between all coats of primer and finish.
3. A minimum of three top coats on all 6 edges is recommended for proper protection.

## Jamb and Threshold Guidelines

1. Caulk at sill-to-jamb leg connection.
2. Use corner pads where sill meets jamb.
3. Install door sweep on door.
4. Completely seal bottom edge of door prior to installation of door sweep. We recommend a latex caulk coating on bottom edge of door prior to door sweep attachment.
5. Seal the bottom of the jamb legs with a caulk coating.

## Installation Guidelines & Roof Overhang

1. The utility or structural strength of the door must not be impaired in fitting to the opening, in applying hardware, or other detailing.
2. Refer to "Preparation for Finishing" on the reverse. Use a sharp, fine-tooth saw for trimming ends of doors.
3. Use a minimum of one hinge for each 30 inches of door height on all exterior doors. When using three or more hinges, they are to be equally spaced. Standard height (6'8") doors require three (3) hinges. Extra height (8'0") doors require four (4) hinges. Quality ball-bearing hinges are recommended for superior service in these hardwood door applications. Hinges must be set in a straight line to prevent distortion.
4. Clearances between door edges and door frame should be a minimum of 1/16" on the hinge edge, and 1/8" on the latch edge and top rail.
5. All hardware locations, preparations for hardware, and methods of hardware attachment must be appropriate for the specific door construction.
6. Immediately after cutting and fitting (before hanging), seal all cut surfaces and ends of door with an effective quality sealer. See finishing recommendation for finishing guidelines. Apply the sealer, primer, or first coats of the required finish immediately after fitting, cutting for hardware, weatherstripping, etc. Be sure to finish all surfaces of the door, including those surfaces milled for the hardware prior to installation of the hardware. Also be sure to finish the top and bottom edges of the door, as well as the sides of the door, prior to installation.
7. **The door or entryway system must be installed in a protected opening with adequate roof overhang to protect the door and/or entryway. Damage may result from exposure due to installation in an unprotected opening, such as an installation without sufficient roof overhang protection.** This will cause the door and/or entry system to be exposed to an unusual amount of direct sunlight and/or precipitation, which will result in the failure of the door or entryway. This damage is specifically not covered by GlassCraft's warranty. When hanging door, allow adequate clearance for swelling of door or frame in damp weather. Allow approximately 3/16" clearance for swelling when the door is installed in fully dry conditions. Jambs must be plumb. See Roof Overhang section.
8. Caution must be used to avoid impairing the strength of the door when fitting for locks. Allow at least 1" of wood back of mortise.
9. Jambs and stops must be set square and plumb.
10. To minimize heat loss and save energy, use weather stripping.
11. Damage caused by failure to comply with appropriate and correct door finishing guidelines, failure to perform normal

homeowner maintenance, or by attempts other than by GlassCraft to repair the door will void the GlassCraft warranty.

## Roof Overhang

Adequate roof overhang depends upon the directional exposure (north, south, east or west) of the entryway, and upon the geographic region of the installation. Minimum roof overhang (see drawing below) is one in which the roof overhang projects out a distance from the structure no less than one-half of the elevation difference between the bottom edge of the door and the base of the overhang's highest point above the entryway. This calculation is shown below.

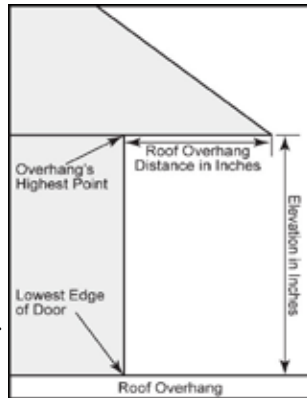

Distance in inches divided by elevation in inches must equal at least 0.5" or greater.

The width of the overhang and/or placement and size of entryway side walls are also very important to adequately protect the entryway. Depending upon the installation application, this overhang may need to be greater than this minimum overhang.

## Maintenance

### Wood Doors

Your GlassCraft hardwood door has been handcrafted to last, but periodic maintenance is required to keep it looking great and provide proper protection against the elements. Regular finish maintenance is also a requirement of the warranty that's included with GlassCraft doors. If you maintain your door properly, it will give you years of enjoyment.

Here are some signs to watch for on your wood door. Ordinarily, your door's finish coating will first begin to deteriorate at the exterior lower portion of the door, so look in this area first. These warning signs indicate that it's time for some simple, easy-to-perform maintenance:

- Hairline cracks in the top coat of finish.
- Changes in the color of the finish.
- Changes in the texture of the finish, such as flaking or scaling.
- A dull or chalky finish.

If you live in a severe climate area or your entry or door receives lots of direct sunlight and/or direct precipitation from a southern or western exposure, you'll want to examine your door's finish often. Depending on the conditions, you may also need to maintain the door finish more frequently.

### Glass Panels

All exterior GlassCraft doors which include a glass panel use a double-thick or triple-thick Insulated Glass Panel Unit. These insulated glass (IG) panels do not require any maintenance, and will last for years with regular installation and use, and are

warranted against IG seal failure. Do not clean the glass with a razor blade, as this can scratch the glass.

## Wrought Iron Grilles

Your GlassCraft door may include a handmade wrought iron grille. These grilles are real wrought iron, and each is unique. All wrought iron grilles are coated to inhibit rusting. But they are iron, and, like any iron or steel item (such as your car), will rust if the painted surface is damaged or scratched. Maintenance is easy. Please refer to "Rust on your wrought iron grille" below.

## Problems with Your Door

**Appearance of the Finish:** Stain-and-clear finishes perform better if protected from direct sunlight, moisture, and other weathering conditions. Refinishing will be required less frequently if a proper finish is initially added to the door. Some finishes on exterior doors deteriorate relatively quickly with exposure to the environment. In order for your exterior door to continue receiving the protection required, inspect the condition of the exterior finish at least twice a year and refinish as often as needed to maintain the protective integrity of the finish. If required refinishing is not completed as needed, you will allow moisture to enter the wood in the door. This will cause the door to warp or crack, and will void any warranty claims. Inspect the finish on all six sides of the door.

**Binding or sticking of the Door:** Ensure that the door(s) continues to swing freely, does not bind in the frame, and that all hardware remains completely functional. If the door begins to stick or bind in the door frame, sand the edge of the door (use an electric sander or a hand plane) to trim the door so that it does not bind or stick. Be sure to refinish the newly sanded exposed area. Usually it takes as long as one year for a wood door to acclimate to its installation surroundings.

**Cleaning the Door:** Cleaning of the door is best performed with a clean cloth. If required, a very mild soap and water solution may be needed to remove dirt from the door. Do not use any abrasive detergent or solvent based product, as these products will harm the quality of the finish.

White or unfinished wood lines around the edges of a door panel are caused by the normal contraction and expansion of the "free floating" panels in the doors. This is due to varying climatic conditions such as dry or hot weather. Use a standard wood stain to touch-up and eliminate this line.

**Rust on your wrought iron grille:** Like any product made of steel or iron, your wrought iron grille will rust if the painted coating is damaged. Should rust appear on your wrought iron grille, simply burnish the affected area with a wire brush, and repaint using a "matte" black paint for steel, such as Rust-Oleum®.

For more information, please refer to  
[www.glasscraft.com](http://www.glasscraft.com)

# Guidelines for Your Hardwood Door

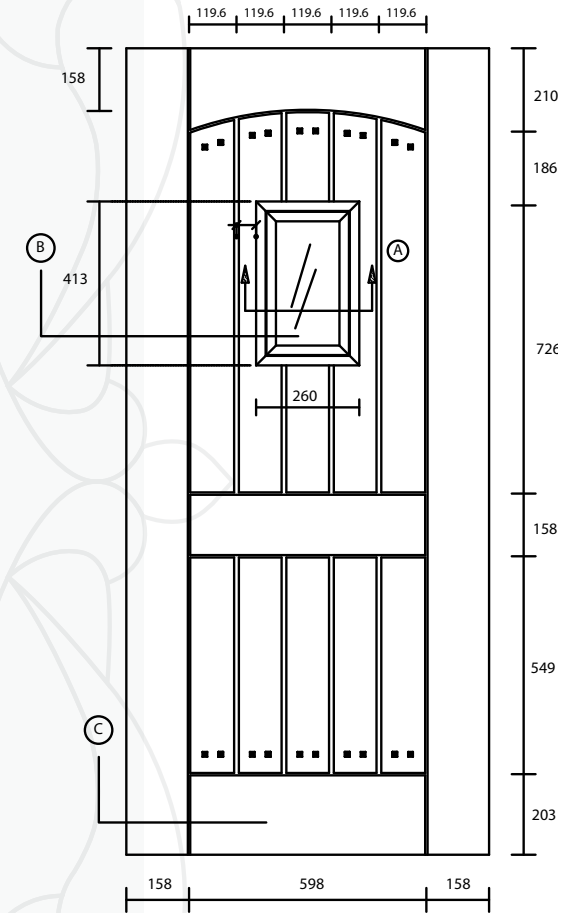

**GLASSCRAFT**  
DOOR COMPANY

The #1 Hardwood Entry Door Company In America.

All photos, drawings, and product designs are copyright 1982-2012 GlassCraft Door Company, Houston, Texas. Any duplication of any part without specific written authorization from GlassCraft Door Company is strictly prohibited.